

Lock Link®

Catenary-Style MultiRake Bar Screen

Slow, Steady, Reliable Screening



Lock Link Screen Installation New Castle Indiana

This type of bar screen technology was first introduced over 20 years ago and still has a place in today's headworks. Whether it is being used as a scalping screen in a two phase debris removal process or as the only headworks screen, it provides the downstream protection consistent with multi-rake bar screens plus the flexibility of the catenary bar screen design.

The Lock Link® screen is a front cleaning, front return type chain operated bar screen. Chain links & cleaning rakes descend on the upstream side of the bar rack. As the chain reaches the bottom of the screen and since it bends in one direction only, it naturally articulates in the opposite direction in a catenary loop without any lower sprocket. The rake engages the bar rack at the channel bottom, captures the debris and moves the debris up the screen to discharge.

The Lock Link screen has new features designed to maintain the flexibility of this screen while increasing the strength and life of the components. The Lock Link can handle debris of various types and sizes. Under normal conditions, the Lock Link operates like a typical multi-rake bar screen. If the screen encounters large debris in the influent flow, the link system locks around the debris and removes it from the stream. If a large object comes between the rake and the screen, the Lock Link system rocks forward. This allows the object to travel up the bar rack, lifting it to the discharge point.

One of the most significant new features is the auto reversing chain rake system. This design feature enables the rake to reposition large objects in the channel so the forward motion of the rake can capture the object and remove it.



Curved Bar Rack at Channel Bottom

Lock Link®

Catenary-Style MultiRake Bar Screen

Lock Link® Screen Features

- Lock Link Chain
 - ✓ 316L SS investment casting
 - ✓ Minimum 60,000# ultimate strength
 - ✓ 316L SS cotter pin and locking pin

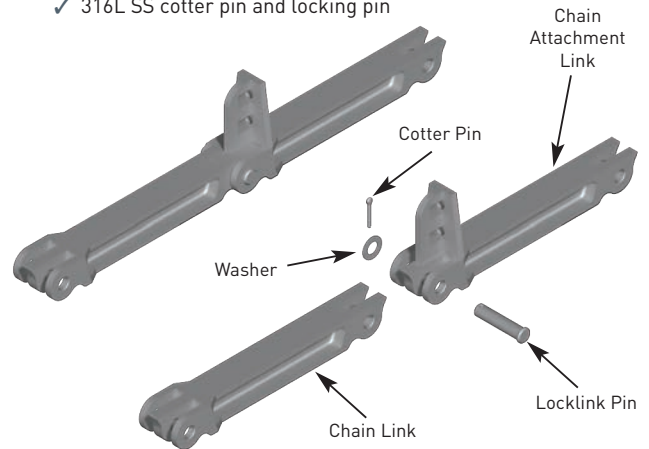

- Tru Reversing System
- Wiper design allows efficient reversing of the chain rake system.
- Adjustable floor anchoring system
- Curved bar rack at channel bottom designed to prevent debris accumulation.
- Adjustable chain guide roller system.
- Odor control covers.

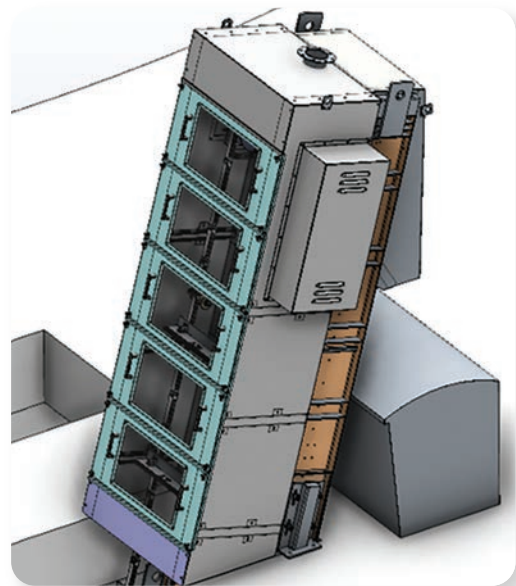
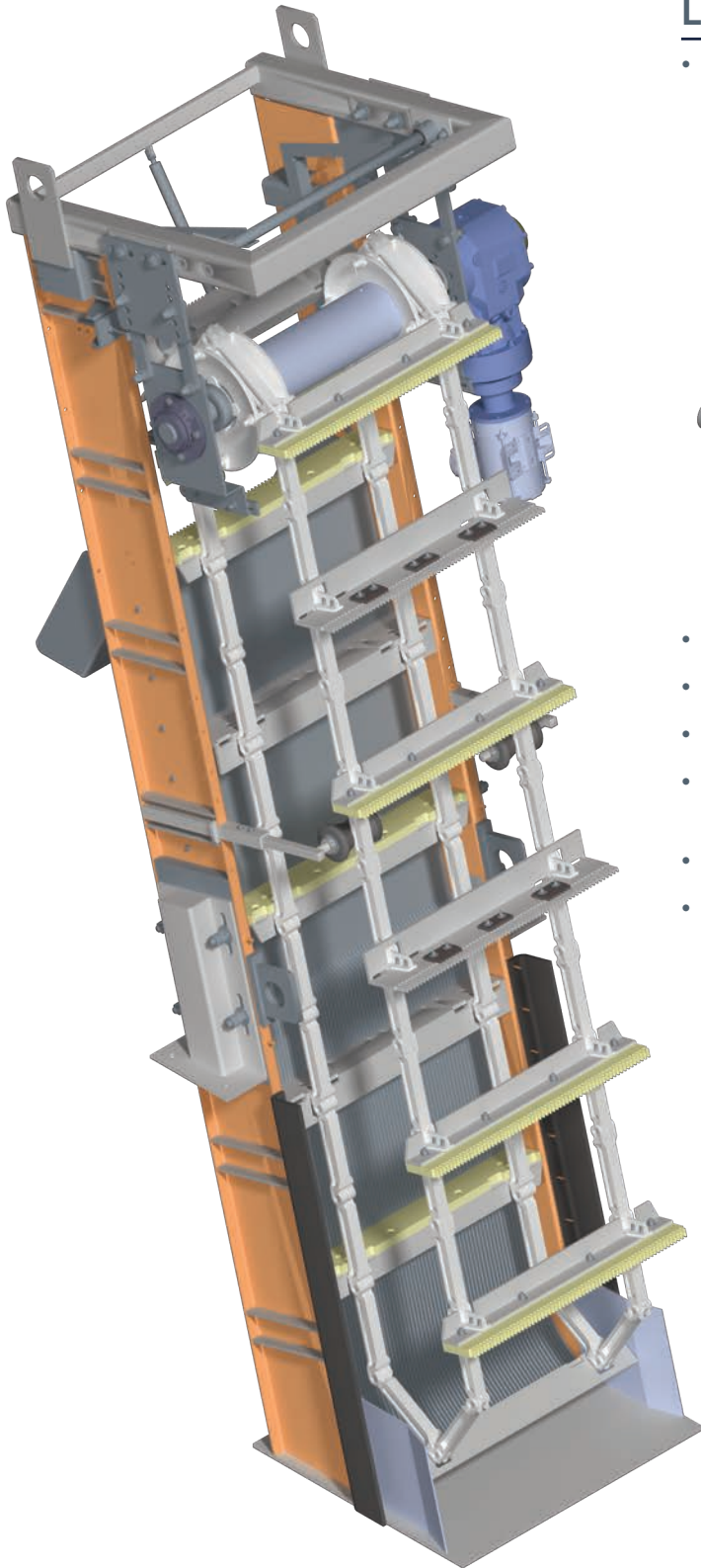

Covers With View Ports

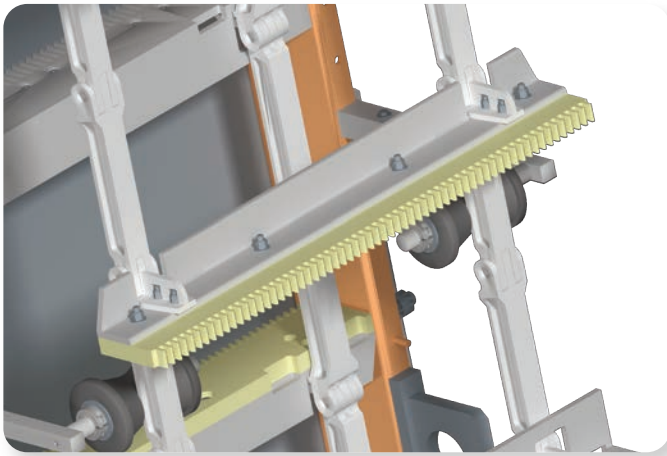

Full Penetration UHMWPE "Thru" Rake

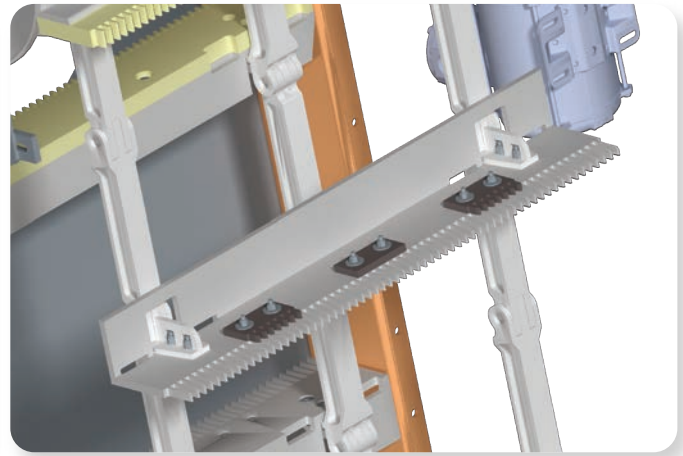

Full Penetration Stainless Steel "Thru" Rake

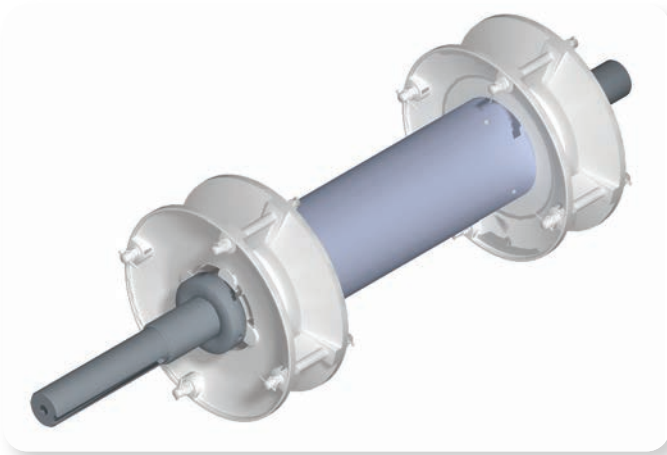

Heavy-duty cast stainless steel drive sprockets with a single through stainless steel drive shaft with a seamless torque tube.

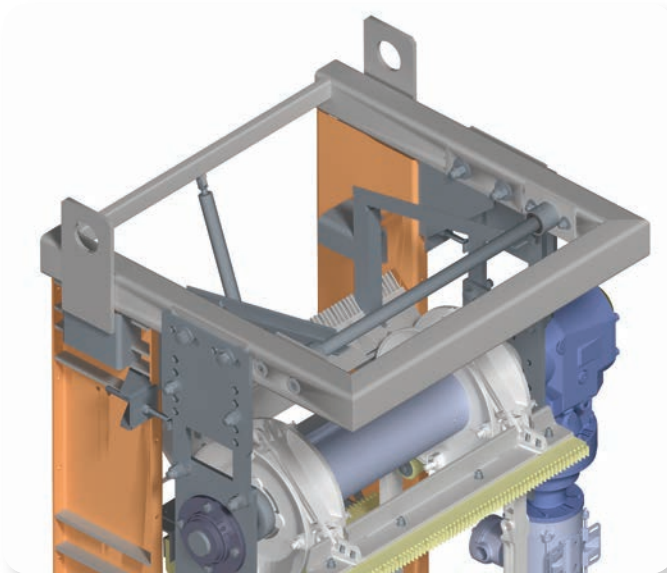

Heavy-duty single piece cast SS head sprocket assembly installed and driven by a cycloidal-style gear reducer.

Advantages

- **Lock Link screens come fully assembled with no site welding required.** Longer screens are available in bolted modular sections.
- **Drive output shaft rotation** is constant, single directional but can be reversed when required. This flexibility does not compromise product life.
- **Auto reversing chain rake mechanism.** The chain rakes do not hit the wiper mechanism when rakes are reversing; and the wiper mechanism does not need to be manually pivoted out of the rake's path.
- **No lower sprockets, bearings or tracks** means less maintenance and wear.
- **Drive sprockets and end castings** are supplied as stainless steel castings.
- **Drive sprocket is a through solid shaft design** which is better able to handle heavy loading and torsion.
- **Chain link system complete with stainless steel pins and stainless steel retaining cotter pins.** Will not corrode and/or loosen and cause improper fit.
- **Scrapers with serrated edge or full combs** are supplied for more thorough cleaning of bars.
- The Lock Link screen has **tapered stainless steel bars** as standard.
- All screens come with a **Five-Year Warranty**.
- Links and cotter pins are **made of 316L SS**.

Lock Link®

Catenary-Style MultiRake Bar Screen

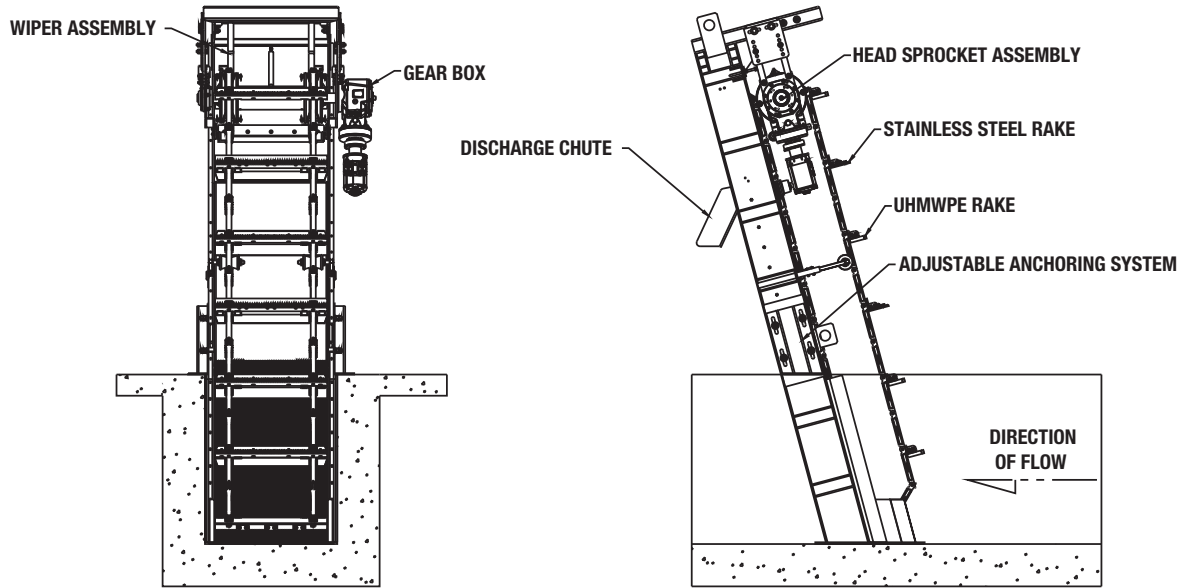

Specifications

Unit Width	1'-8" to 10'-0"
Unit Length	10' to 100'
Bar Spacing	6mm to 90mm
Angle of Inclination	45° to 80°
Optimum Angle	60° to 70°



Lock Link screen arrives fully assembled or with bolted modular pieces for deep channels.

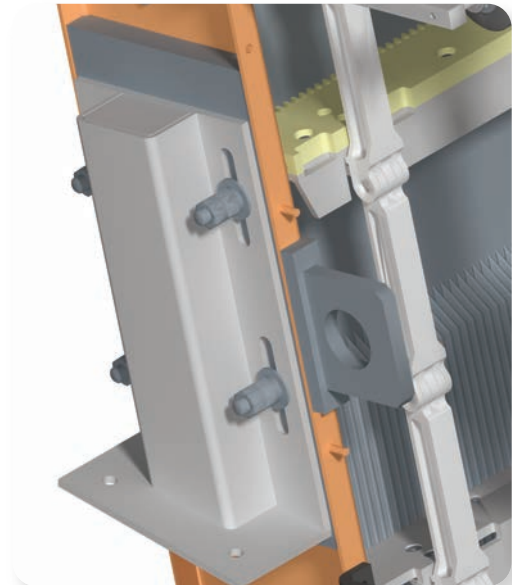

Adjustable floor anchoring system